

Procedure for Changing the Position of a Valve Gear Operator on Site

IMPORTANT: For the following procedure you will need to know the rated input torque for your valve. This can be found in the catalog on line at www.scorevalves.com or by contacting Score with your valve serial #. It is important that you are sure you have the correct information because some valves are have reduced torque ratings owing to special materials or operating conditions.

You will also need to know the mechanical advantage of the gear operator that is installed on your valve. This can be found from the gear operator model number and the tables at the end of this document or from the gear operator manufacturer.

Before commencement of work on valve, review and perform all due diligence related to safe work documentation and practices required by plant owner company.

Insure there is no pressure on either side of valve and the lines are locked out in both directions.

Removing the Gear Operator.

1. Close the valve fully by turning the gear operator to the end of stops*. **Note:** This assumes that the actuator stops have not been altered since Factory Set-up.
2. Back the gear operator off slightly to relieve all torque on shaft.
3. Remove the gear operator mounting bolts.
4. Remove the gear operator from the shaft. Note: the key(s) will stay with the shaft.
5. Remove the key(s) from the shaft.
6. Remove the staking imprint from the end of the shaft by filing or another suitable means. Insure the key(s) will freely slide axially onto the shaft. Also insure that the key(s) will slide axially into the gear operator hub from the outside.

Re-installing the Gear Operator.

7. Reposition the gear operator to the desired position then insert onto the valve shaft.
8. Replace the gear operator mounting bolts and torque to spec.
9. Rotate the gear operator handwheel as required to line up the keyways. (usually not more than a few degrees)
10. Remove cover plate from face of gear operator.
11. Insert the key. Tap into place if required.
12. Stake the end of the shaft with a center punch to prevent the key from coming out during operation.
13. Re-install cover plate.
14. Back the gear operator off (opening the valve) until the torque required to turn the handwheel drops off significantly. This indicates that the valve is now unseated.
15. Back off the gear operator closing stop 2 or 3 turns.



Setting the Stops on the Gear Operator.

Calculate the design input torque for the gear operator.

Example: for a full-rated 24" Class 150 Valve: Max shaft input torque (from catalog): Use the column "Full Rated at 285 psi, Seating". = 38,000 in-lbs

Note the model number of the gear operator to find the Mechanical Advantage.

Example: Diamond Gear 63WG296. Mechanical Advantage = 66.7 (from tables)

Design input torque for the gear operator:

$$38,000 / 66.7 = 570 \text{ in-lbs} \Rightarrow 48 \text{ ft-lbs}$$

16. Commence closing the valve with the gear operator handwheel and continue until the torque just starts to increase.

Important: the following steps require an accurate means of measuring the input torque on the gear actuator input stem. The preferred method is to fit stem with an adaptor so that a torque wrench can be used.

17. Remove the handwheel and install an adaptor for a torque wrench. Using the torque wrench, torque the input stem to torque calculated above.

18. Set the closing stop by turning in until the stop contacts the gear quadrant and lock the stop in place.

19. Fully open the valve until the gear operator position indicator has turned 90 degrees to verify that the valve is opening fully. The valve open stop should not require adjustment.

Any questions regarding this procedure should be directed to the attention of:

Brent Fraser, P. Eng.
Engineering Manager,
Score Energy Products Inc
Phone: (780) 466-6782, email: eng@scorevalves.com

Diamond Gear

WORM GEAR TECHNICAL DATA

Gear Model No.	Weight (lbs.)	Output Torque In-LBS	Mechanical Advantage	Ratio	No. of Turns to Open	Max. Stem Diameter	Max. Bolt Circle	Min. Bolt Circle	Preferred Bolt Circle	Input Shaft Diameter
2.5WG50	9	2,500	13.0	50	12.50	0.875	4.00	2.75	FA07,FA10	0.625
5WG48	15	5,000	12.5	48	12.00	1.13	4.25	2.75	FA07,FA10	0.750
8WG50	20	8,000	12.5	50	12.50	1.63	5.13	3.70	FA10,FA12	0.750
13WG56	26	13,000	15.1	56	14.00	1.88	5.50	4.50	FA12,FA14	0.750
18WG64	43	18,000	18.0	64	16.00	2.50	7.00	5.13	FA14,FA16	0.750
26WG68	61	26,000	19.0	68	17.00	2.88	8.00	6.00	FA16,FA19	1.000
43WG72	80	43,000	18.0	72	18.00	3.25	8.50	6.25	FA16,FA19	1.000
43WG216	107	43,000	48.6	216	54.00	3.25	8.50	6.25	FA16,FA19	0.875
63WG74	112	63,000	18.5	74	18.50	4.00	10.25	7.75	FA25	1.250
63WG296	139	63,000	66.7	296	74.00	4.00	10.25	7.75	FA25	1.000
93WG52	137	93,444	19.8	52	13.00	4.25	11.75	7.50	FA25	1.181
93WG312	210	93,444	116.1	312	78.00	4.25	11.75	7.50	FA25	1.181
95WG348	225	95,000	84.6	348	87.25	4.00	10.50	8.25	FA25	1.250
140WG372	241	140,000	104.2	372	93.00	4.25	10.50	8.75	FA25	1.250
147WG408	280	147,728	166.3	408	102.00	5.50	14.50	9.50	FA25,FA30	1.181
210WG560	483	210,000	146.2	560	140.00	5.75	14.25	11.75	FA30	1.250
266WG488	528	266,327	174.2	488	122.00	6.25	17.50	10.50	FA30,FA35	1.181
266WG1464	566	266,327	470.4	1464	366.00	6.25	17.50	10.50	FA30,FA35	0.787
275WG468	460	275,000	117.0	468	117.00	6.00	17.25	12.25	FA35,FA40	1.250
275WG1404	540	275,000	335.4	1404	351.00	6.00	17.25	12.25	FA35,FA40	1.000
408WG576	750	408,000	166.0	576	144.00	6.75	17.50	13.30	FA36,FA40	1.250
408WG1728	820	408,000	448.0	1728	432.00	6.75	17.50	13.30	FA36,FA40	1.000
509WG610	784	509,714	220.7	610	152.00	7.87	20.00	12.50	FA40	1.181
509WG1830	811	509,714	595.9	1830	457.50	7.87	20.00	12.50	FA40	0.787
509WG2440	814	509,714	794.5	2440	610.00	7.87	20.00	12.50	FA40	0.787
555WG610	720	555,000	129.1	610	152.00	6.75	19.50	15.50	FA40,FA48	1.250
555WG2440	800	555,000	504.5	2440	610.00	6.75	19.50	15.50	FA40,FA48	1.000
825WG1571	1300	825,000	452.6	1571	393.00	8.00	22.50	16.50	FA48	1.969
962WG1600	1496	962,563	611.0	1600	400.00	10.20	24.50	15.50	FA48	1.181
825WG1571	1300	825,000	452.6	1571	393.00	8.00	22.50	16.50	FA48	1.969
1136WG1125	1460	1,136,000	324.6	1125	281.00	9.00	24.00	17.50	FA48	1.375
1136WG3375	1540	1,136,000	916.1	3375	843.00	9.00	24.00	17.50	FA48	1.000
1136WG1714	1485	1,136,000	493.7	1714	428.50	9.00	24.00	17.50	FA48	1.969
1401WG1600	2912	1,401,580	652.0	1600	400.00	12.50	24.50	19.00	FA48,FA60	1.575
1590WG1266	2470	1,590,000	410.1	1266	316.50	12.00	27.00	23.50	FA60	2.360
2500WG3822	6640	2,500,000	1238.85	3822	956.00	13	34	23.50	FA48,FA60	2.360

15740 Park Row, Suite 100 - Houston, Texas 77084

Ph: 1-281-578-6666 F: 1-281-578-2797

www.bernardcontrols.com

QUARTER TURN TECHNICAL DATA

MANUAL UNITS

Description	Output Torque (In-lbs)	Output Torque (Nm)	Mechanical Advantage	Turns To Close	Bore Diameter (In. max.)	Mounting Patterns	Stem Entry (In. max.)
M05	1,320	149	9.3	10	0.98	F/FA05, F/FA07	2.01
M07	2,640	298	11	10	0.98	F/FA05, F/FA07	2.01
M10	5,280	597	11	10	1.26	F/FA07, F/FA10	2.24
M12	10,560	1,193	11.3	10.5	1.77	F/FA10, F/FA12, F/FA14	2.83
M14	19,360	2,188	16.2	15	2.56	F/FA12, F/FA14, F/FA16	3.19
M15	36,080	4,077	20.5	17	3.39	F/FA14, F/FA16, F/FA20	3.62
M16	47,520	5,370	26.5	22	3.62	F/FA16, F/FA20, F/FA25	4.45

NOTE: RATINGS ABOVE ARE FOR 1000 CYCLES.

MANUAL / ADAPTABLE--MOTORIZABLE UNITS

Description	Output Torque (In-lbs)	Output Torque (Nm)	Mechanical Advantage	Turns To Close	Bore Diameter (In. max.)	Bolt Circle Straddling (In. max.)	Bolt Circle On Center (In. max.)	Bolt Circle (In. min.)	Stem Entry (In. max.)
MZF40	3,500	395	10.8	10.00	1.25	4.25	3.00	2.63	2.24
MVF31	9,000	1,017	9.1	7.75	1.75	5.00	5.00	3.38	2.91
MYF40	12,000	1,356	10.0	10.00	1.75	5.00	5.00	3.38	3.03
MAF46	15,000	1,695	11.6	11.50	2.50	6.50	4.75	4.25	3.13
MBF64	21,000	2,373	18.7	16.00	2.50	8.25	6.00	4.50	3.43
MCF72	30,000	3,390	19.4	18.00	3.25	8.50	6.00	5.50	3.58
MFF57/S3	55,000	6,215	44.5	42.75	3.50	10.50	10.50	6.50	4.49
MFF36/S5	70,000	7,910	52.0	45.00	3.50	10.50	10.50	6.50	4.49
MJF50/S5	105,000	11,864	73.0	62.50	4.50	11.75	11.75	7.25	5.50
MJF50/D9	105,000	11,864	116.6	113.00	4.50	11.75	11.75	7.25	5.50
MLF60/D12	210,500	23,785	156.5	180.00	6.50	14.02	14.02	9.25	5.91
MLF60/D9/S3	210,500	23,785	301.0	406.80	6.50	14.02	14.02	9.25	5.91
MPF50/D12/S3	420,000	47,458	384.2	450.00	6.50	15.98	15.98	9.25	7.01
MPF50/D15/S3	420,000	47,458	480.0	561.88	6.50	15.98	15.98	9.25	7.01
MTF50/DB6/D9	700,000	79,096	520.3	674.75	8.66	19.00	19.00	12.50	8.86
M83/DB9/D9	996,000	112,542	669.8	813.50	8.66	19.00	19.00	12.50	8.86
M125/DB9/D9	1,500,000	169,492	1052.7	1138.90	10.83	23.60	23.60	16.00	12.99
M160/DB9/D9	1,920,000	216,949	1314.7	1423.63	12.20	26.00	26.00	18.00	14.37
M200/DB9/D9	2,400,000	271,186	1623.7	1769.38	13.78	29.25	29.25	20.00	15.87

NOTE: FOR 500 AND 1000 CYCLE TORQUE RATINGS PLEASE REFER TO SPECIFIC GEARBOX BROCHURES



MASTERGEAR

DIVISION OF REGAL-BELOIT CORPORATION
5466 EAST ROCKTON RD. SOUTH BELOIT, IL 61080

REV. C
8/28/02

**Preferred
Direction of Flow
or Pressure**

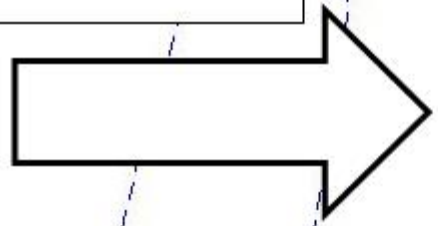

**Conical shaped body
seat and disc seal.**

**Non-Preferred
Direction of Flow
or Pressure**

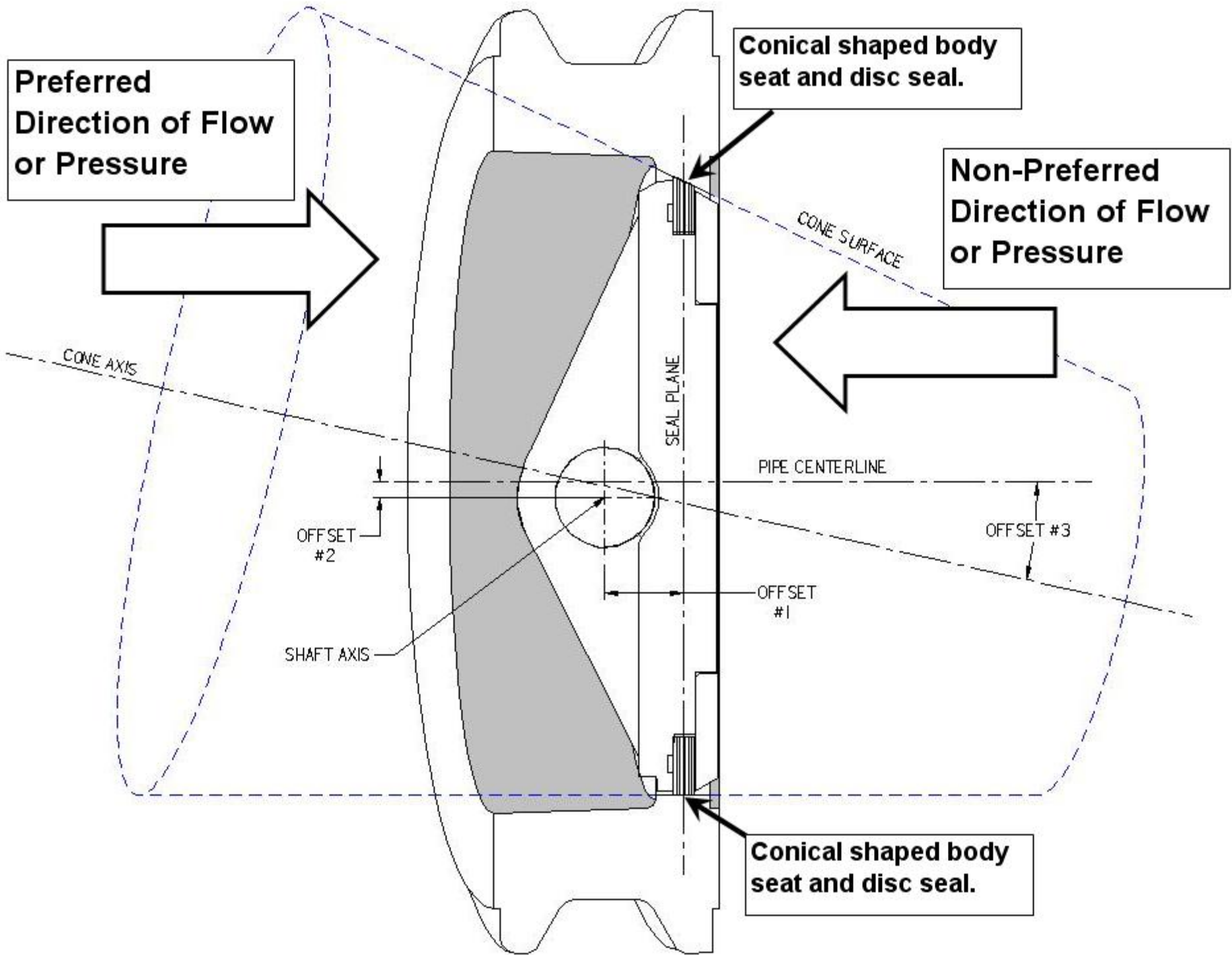
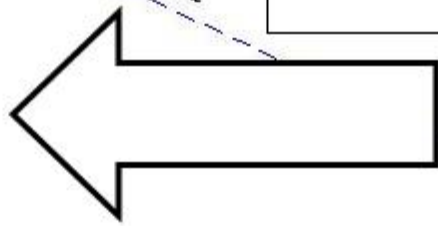

SEAL PLANE

CONE SURFACE

CONE AXIS

PIPE CENTERLINE

OFFSET #2

OFFSET #3

OFFSET #1

SHAFT AXIS

**Conical shaped body
seat and disc seal.**